

SIEMENS

SIMATIC S7 Graph for S7-300/400 Programming Sequential Control Systems

Getting Started

Edition 04/2001

First Steps

The Getting Started for this product is not a stand-alone description. It is a part of the manual and can be called via "First Steps".

First Steps

Product Information System



Safety Guidelines

This manual contains notices intended to ensure personal safety, as well as to protect the products and connected equipment against damage. These notices are highlighted by the symbols shown below and graded according to severity by the following texts:



Danger

indicates that death, severe personal injury or substantial property damage will result if proper precautions are not taken.



Warning

indicates that death, severe personal injury or substantial property damage can result if proper precautions are not taken.



Caution

indicates that minor personal injury can result if proper precautions are not taken.

Caution

indicates that property damage can result if proper precautions are not taken.

Notice

draws your attention to particularly important information on the product, handling the product, or to a particular part of the documentation.

Qualified Personnel

Only **qualified personnel** should be allowed to install and work on this equipment. Qualified persons are defined as persons who are authorized to commission, to ground and to tag circuits, equipment, and systems in accordance with established safety practices and standards.

Correct Usage

Note the following:



Warning

This device and its components may only be used for the applications described in the catalog or the technical description, and only in connection with devices or components from other manufacturers which have been approved or recommended by Siemens.

This product can only function correctly and safely if it is transported, stored, set up, and installed correctly, and operated and maintained as recommended.

Trademarks

SIMATIC®, SIMATIC HMI® and SIMATIC NET® are registered trademarks of SIEMENS AG.

Third parties using for their own purposes any other names in this document which refer to trademarks might infringe upon the rights of the trademark owners.

Copyright © Siemens AG 2001 All rights reserved

The reproduction, transmission or use of this document or its contents is not permitted without express written authority. Offenders will be liable for damages. All rights, including rights created by patent grant or registration of a utility model or design, are reserved.

Disclaimer of Liability

We have checked the contents of this manual for agreement with the hardware and software described. Since deviations cannot be precluded entirely, we cannot guarantee full agreement. However, the data in this manual are reviewed regularly and any necessary corrections included in subsequent editions. Suggestions for improvement are welcomed.

3 Designing a Sequential Control System Based on the Example of a Drill

Welcome to the S7 Graph Beginner's Example

If you take an hour to work through the beginner's example, you will learn how to create a sequential control system for automating the drill as described below.

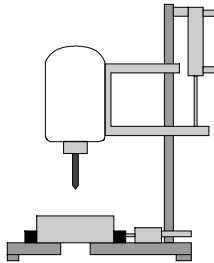

You first learn how to configure a sequential control system efficiently and will then be guided step by step through the tasks you need to perform in the SIMATIC Manager and in S7 Graph so that you can

- create the sequential control system,
- download it to the CPU and
- test it.

The correctly programmed sample is supplied with S7 Graph as a project called "ZEn02_01_S7Graph_Drill".

Requirements

To allow you to program and test the "drill" example, you require the following hardware and software:

- Programming device/PC with
 - STEP 7 standard package and the S7 Graph optional package
 - MPI connection to the programmable logic controller
- A programmable logic controller (in our example an S7-300) consisting of the following: standard rail, 24V power supply, CPU 314, and a digital input/output module (8DI + 8DO)
- As an alternative to the PLC: The "PLC Simulation" S7 optional package

Procedure for Creating a Sequential Control System

The flow diagram illustrates the procedure for creating the sequential control system for the drill example:

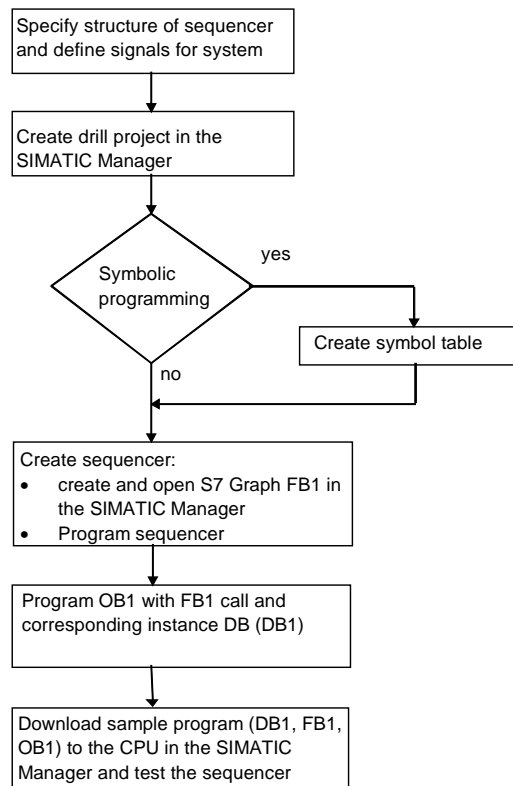

3.1 Technological Task and Functional Diagram

Task

You want to program a sequential control system to automate a drill. The setup of the drill is shown by a technological drawing and the process sequence in the form of a function diagram.

Technological Drawing - Set Up of the Drill

The drill consists of the following elements:

- Drill motor with feedback signals for drill running/stopped
- Start button and coolant switch
- Cooling pump with feedback signal for coolant pressure reached
- Clamping device with feedback signal for selected clamp pressure reached
- Carriage raise/lower drill with limit switches for drill up/down

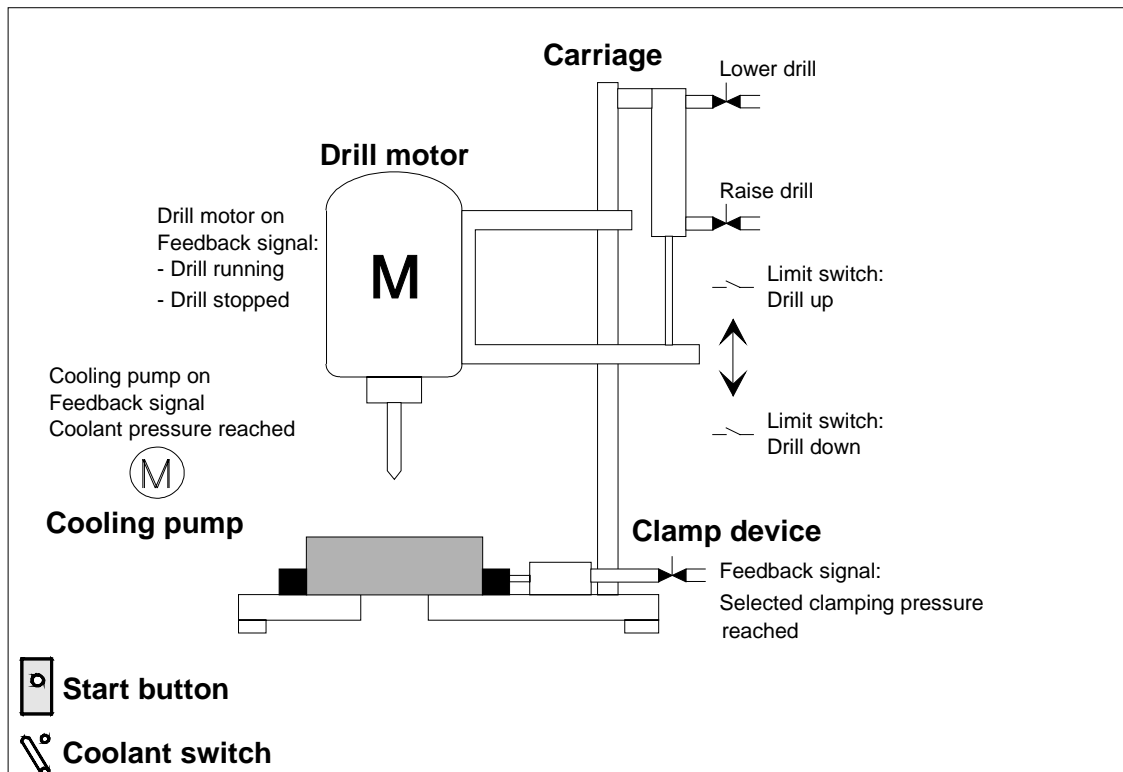

Initial State

The initial state of the drill is defined as follows:

- The drill motor and cooling pump are stopped
- The carriage/drill is in the upper position
- There is no work piece in the clamping device

Functional Diagram - Drilling Sequence

The entire drilling sequence can be divided into the following sections:

- Insert work piece (manual)
- If required, set switch for coolant (depending on the material)
- Start the machine with the start button (drill motor starts up)
- Clamp the work piece with the selected clamp pressure
- Start the cooling pump (if coolant selected)
- Lower drill and carriage to the bottom target position (drill)
- Wait 0.5 seconds at lower target position (drill)
- Raise drill with carriage to upper target position
- Remove work piece, turn off drill motor and cooling pump
- Remove work piece (manual)

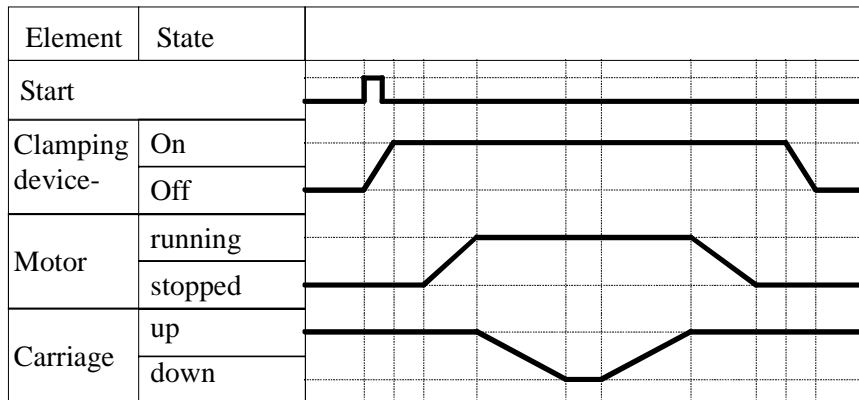

3.2 Selecting the Structure of the Sequencer

Before you create the program for the sequencer, you should include a concept phase in which you break down the drilling operation into single steps. The basis of the concept design is the technological drawing and the flowchart.

Dividing the Drilling Process into Individual Steps - Structure of the Sequencer

The drilling process is described by S7 Graph in the form of a sequencer. A sequencer represents a sequence of single steps and conditions that control how the process moves on to the next single step. To specify the structure of the sequencer, follow the steps outlined below:

1. Break down the drilling process into steps and specify the order of the steps (for example "step S2 follows S1" or "step S3 follows either step S4 or S7").
2. For each step, specify the actions that must be performed in the step (for example in S1 the action "Drill ready" or in S3 the action "Turn on drill motor").
3. Then decide for every step which conditions must be met so that the process can move on to the next step (for example for T1 the condition "Drill started - start button pressed" or for T5 the condition "Drill in upper position").

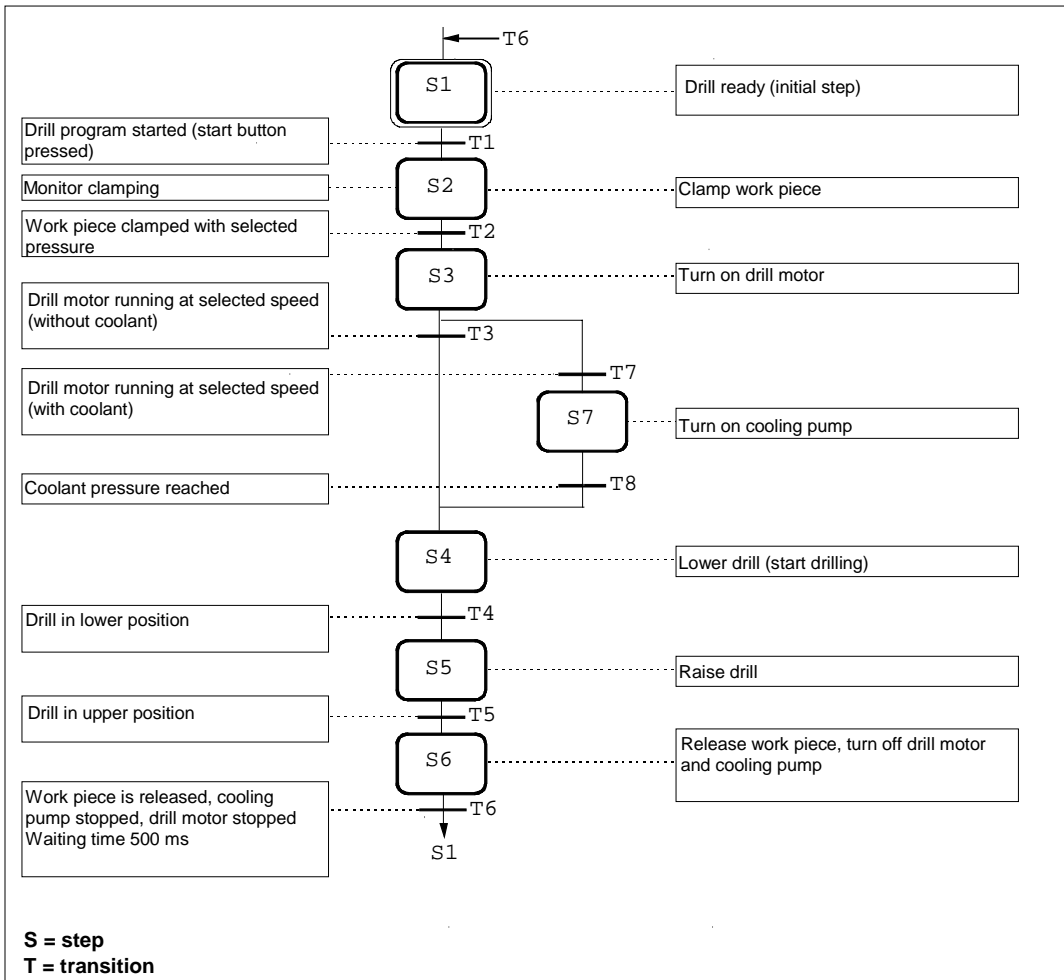

3.3 Defining the System Signals

Once you have broken down the drilling operation into individual steps, you should then define the input and output parameters for each step. The basis of the concept design is the technological drawing and the flowchart.

Defining Inputs and Outputs

List the inputs and outputs for the drill in the form of a table.

If you want to program symbolically, enter the required symbolic names (for example input I 0.4 "Cl_press_ok") for the absolute inputs and outputs and any comments that will make the program easier to understand (for example "Workpiece clamping pressure reached").

In the drill example, it is assumed that the switches and contactors of the drill are controlled via the inputs and outputs of the digital input/output module of the S7-300 programmable controller. The input/output module has 8 inputs and 8 outputs. The default values of the input and output addresses of the module inserted in slot 4 are as follows: I 0 to I 0.7 and Q =0.0 to Q 0.7.

Absolute Addresses	Symbolic addresses	Explanation
Inputs	in the program (I)	
I 0.0	Dr_mot_running	Feedback signal for drill running at selected speed
I 0.1	Dr_mot_stopped	Feedback signal for drill stopped
I 0.2	Drill_down	Limit switch for drill in lower position
I 0.3	Drill_up	Limit switch for drill in upper position
I 0.4	Cl_press_ok	Feedback signal for work piece clamping pressure reached
I 0.5	Coolant_sel	Selector for coolant (dependent on work piece)
I 0.6	Cool_press_ok	Feedback signal for coolant pressure reached
I 0.7	Start_button	Start button of the drill
Outputs	in the program (Q)	
Q 0.0	Dr_mot_on	Turn on drill motor
Q 0.1	Cool_pump_on	Turn on cooling pump (dependent on work piece)
Q 0.2	Lower_drill	Lower drill and carriage to bottom limit position
Q 0.3	Raise_drill	Raise drill and carriage to the upper limit position
Q 0.4	Clamp_workp	Clamp work piece at required pressure

3.4 Creating the Drill Project in the SIMATIC Manager

Creating a Project

Projects for sequential control systems do not differ from other projects in STEP 7.

To create a new project in the SIMATIC Manager, follow the steps outlined below:

1. Select the menu command **File > New**.
2. Name the project "Drill".

Inserting an S7 Program

In this example, hardware configuration is unnecessary since the default addressing of the input/output module in slot 4 is used. You can therefore immediately insert an S7 program in the project folder in the SIMATIC Manager. The S7 program serves as a folder for the blocks of the user program, the source files and the symbols. Follow the steps below:

1. Select the "Drill" project.
2. Select the menu command **Insert > Program > S7 Program**.
3. Name the S7 program "Drill Program".

The folders for source files, blocks, and symbols are created automatically when you insert an S7 program. An empty OB1 is also created in the Blocks folder.

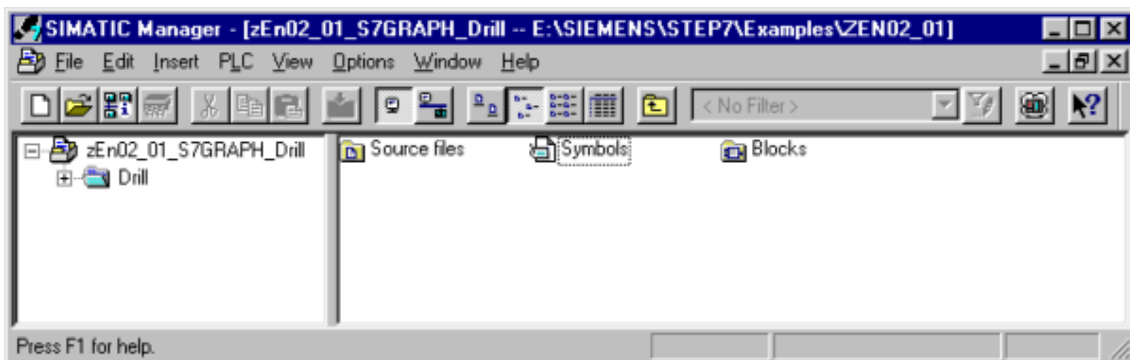

3.5 Creating a Symbol Table

When you program in STEP 7, you work with addresses such as I/O signals, memory bits, counters, timers, data blocks, and function blocks. You can access these addresses in your program in absolute format (for example I1.1, M2.0, FB21).

You will find the program much clearer and easier to read if you use symbols (for example Motor_A_on) instead of the absolute addresses. To allow the use of symbols, you can enter a name, the absolute address, the data type and a comment for every address used.

Once you have defined a symbol, it can be used throughout the entire user program of a programmable module.

Creating a Symbol Table

If you want to write your program using symbolic addresses, it is advisable to create the symbol table at this point.

1. Open the symbol table in the "Drill Program" folder by double-clicking "Symbols".
2. Edit the table as shown below.
3. Save the symbol table using the menu command **Table > Save**.

The entries 1 to 14 are required for symbolic representation of the inputs and outputs. The entries 15 to 18 allow symbolic representation of the blocks.

	Symbol	Address	Data type	Comment
1	Dr_mot_running	I 0.0	BOOL	Drill motor running at selected speed
2	Dr_mot_stopped	I 0.1	BOOL	Drill motor stopped
3	Drill_down	I 0.2	BOOL	Limit switch "drill in lower position"
4	Drill_up	I 0.3	BOOL	Limit switch "drill in upper position"
5	Cl_press_ok	I 0.4	BOOL	Work piece clamping pressure reached
6	Coolant_sel	I 0.5	BOOL	Cooling pump selector switch on
7	Cool_press_ok	I 0.6	BOOL	Cooling pump running
8	Start_button	I 0.7	BOOL	Start button of the drill
9	INIT_SQ	M 0.0	BOOL	Sequencer parameter: INIT_SQ
10	Dr_mot_on	Q 0.0	BOOL	Turn on drill
11	Cool_pump_on	Q 0.1	BOOL	Supply coolant
12	Lower_drill	Q 0.2	BOOL	Lower drill
13	Raise_drill	Q 0.3	BOOL	Raise drill
14	Clamp_workp	Q 0.4	BOOL	Clamp work piece at required pressure
15	IDB_Seq_drill	DB 1	FB 1	Instance DB of the drill sequencer
16	Seq_drill	FB 1	FB 1	Drill sequencer
17	Cyclic_prg	OB 1	OB 1	Cyclic program
18	TIME_TCK	SFC 64	SFC 64	Time Tick
19				

3.6 Creating an S7 Graph FB and Programming a Sequencer

Creating an S7 Graph FB

The S7 Graph FB will contain the sequencer. To create an S7 Graph FB, follow the steps outlined below:

1. Open the "Blocks" folder in "Drill Program" in the SIMATIC Manager.
2. Select the menu command **Insert > S7 Block > Function Block**.
3. Set "S7 Graph" as the language in the "Properties" dialog box.





Result: The empty FB with the default number 1 is created in the "Blocks" folder.

Programming a Sequencer

After you have started the S7 Graph editor by double-clicking FB1 the system inserts the first step (initial step) and the first transition. It is advisable to create the structure at the "Sequencer" display level. To display conditions and actions, activate the **View > Display With > Conditions and Actions** menu command.





Using the mouse and the "Sequencer" toolbar at the left-hand edge of the screen, you can then position all the remaining **steps** and **transitions**, the **alternative branch** and the **jump** from the end of the sequencer to the start of the sequencer. There are two ways of doing this and both are illustrated here.

Method 1: "Direct" Mode

1. Select transition 1 and click with the mouse until the icon  **insert step + transition** until you arrive at step/transition 6.
2. Select step 3 and then select the icon  **open alternative branch.**
This opens the alternative branch for supplying coolant. The branch begins with transition 7.
3. With the mouse, select the icon  **insert step + transition,** and insert step 7 (S7) and transition 8 (T8).
4. Select the icon  **close alternative branch** and then select transition 3.
5. Now complete the sequencer structure by first selecting transition 6 and then clicking on the icon  **insert jump** and then selecting step 1.

Method 2: "Drag-and-Drop"

1. Return to the SIMATIC Manager and create function block FB2 in the "Blocks" folder as described above. Once again select "GRAPH" as the source language.
2. Start the S7 Graph editor by double-clicking FB2 in the "Blocks" folder.
3. Select the menu command **Insert > Drag-and-Drop.**

4. With the mouse, select the icon  **insert step + transition** and then click on the last transition of the individual elements until you arrive at step/transition 6.
5. Select the icon  **open alternative branch** and open the alternative branch for the coolant by clicking on step 3. The branch begins with transition 7.
6. With the mouse, select the icon  **insert step + transition**, to insert step 7 (S7) and transition 8 (T8).
7. Select the icon  **close alternative branch** and first select transition 8 and then transition 3.
8. Now complete the sequencer structure with  **insert jump** by first selecting transition 6 and then step 1.

Note

Before you start to program step actions, close function block FB2. You only created this FB to try out the second method of creating a sequencer structure. When you close the FB, answer all prompts with "No". For the rest of the exercise, you will be working in FB1.

3.7 Programming Step Actions

There are also two methods available for programming step actions and transitions: **Direct** and **Drag-and-Drop**. The procedure described below assumes you have selected the menu command **Insert > Drag-and-Drop**:

1. Select the menu command **Insert >** .
Result: The mouse pointer then appears as shown below:



2. Insert an empty action line by clicking the action box.
3. Enter the actions.

An action consists of an instruction and an address. For the drill program, four different instructions are necessary in the steps:

- S Set output
- R Reset output
- N Non holding: As long as the step is active, the signal state of the address is 1.
- D Delay: The address is set to 1 after the defined time has elapsed following activation of the step and is reset when the step is deactivated.

3.8 Programming Transitions

The bit logic instructions "normally open contact", "normally closed contact" and "comparator" are used for the step enabling conditions in the transitions. To program transitions:

1. Set the "LAD" view and select the appropriate icons in the "LAD/FBD" toolbar



insert normally-open contact



insert normally-closed contact



insert comparator

2. Position the symbols at the appropriate points by clicking the transition lines. You can exit the insert mode at any time with the ESC key.
3. Enter the addresses. Click the placeholder "??." of the required text field. Then enter an absolute or symbolic address (for example I 0.7, "Start_switch").
4. If you wish, you can also enter a comment for the sequencer. In the "sequencer" view, the comment field is at the top left and can be opened by clicking it with the mouse.

The following figure shows the completed sequencer.

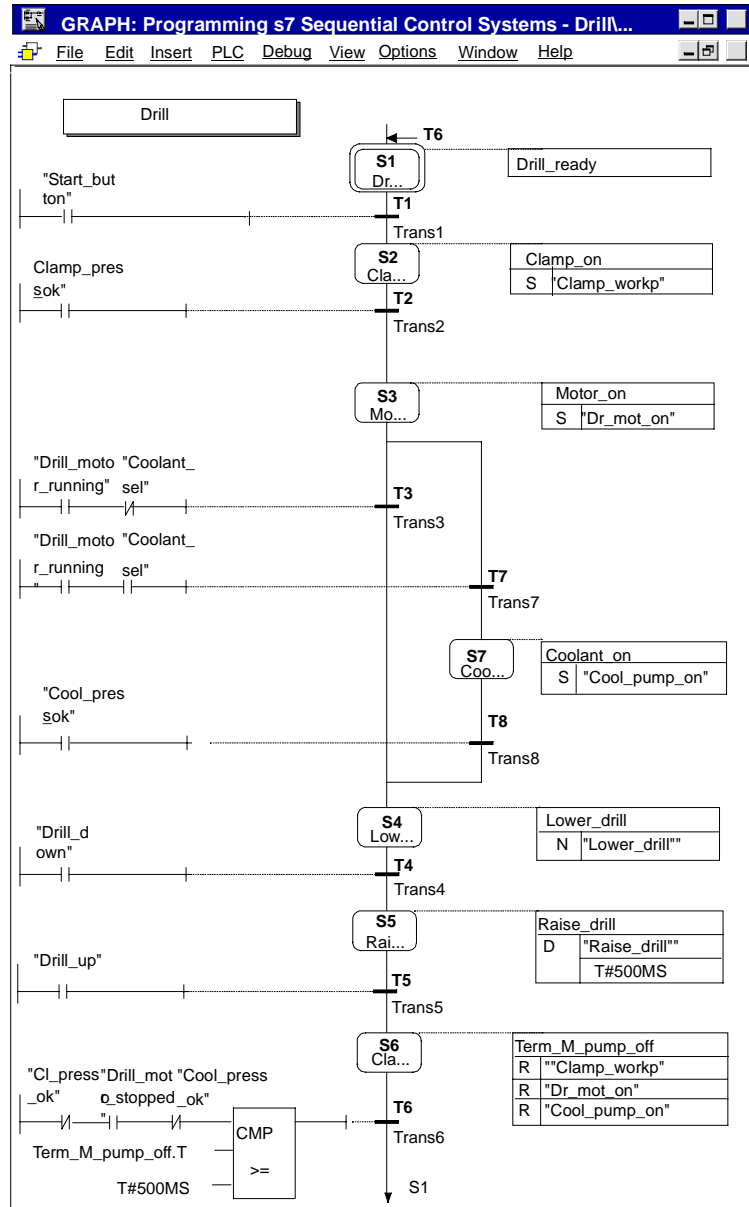

When programming comparators, you can use the system information for steps as the addresses. The addresses have the following significance:

- **Step_name.T:** current or last activation time of the step
- **Step_name.U:** current or last activation time of the step without the time of a disturbance

3.9 Programming Monitoring Functions

To program monitoring functions:

1. Double-click on step 2 to change from the "sequencer" view to the "single step" view.
2. Select the icon  insert comparator in the "LAD/FBD" toolbar
3. Position the comparator at the appropriate point on the supervision line and enter the required monitoring time.

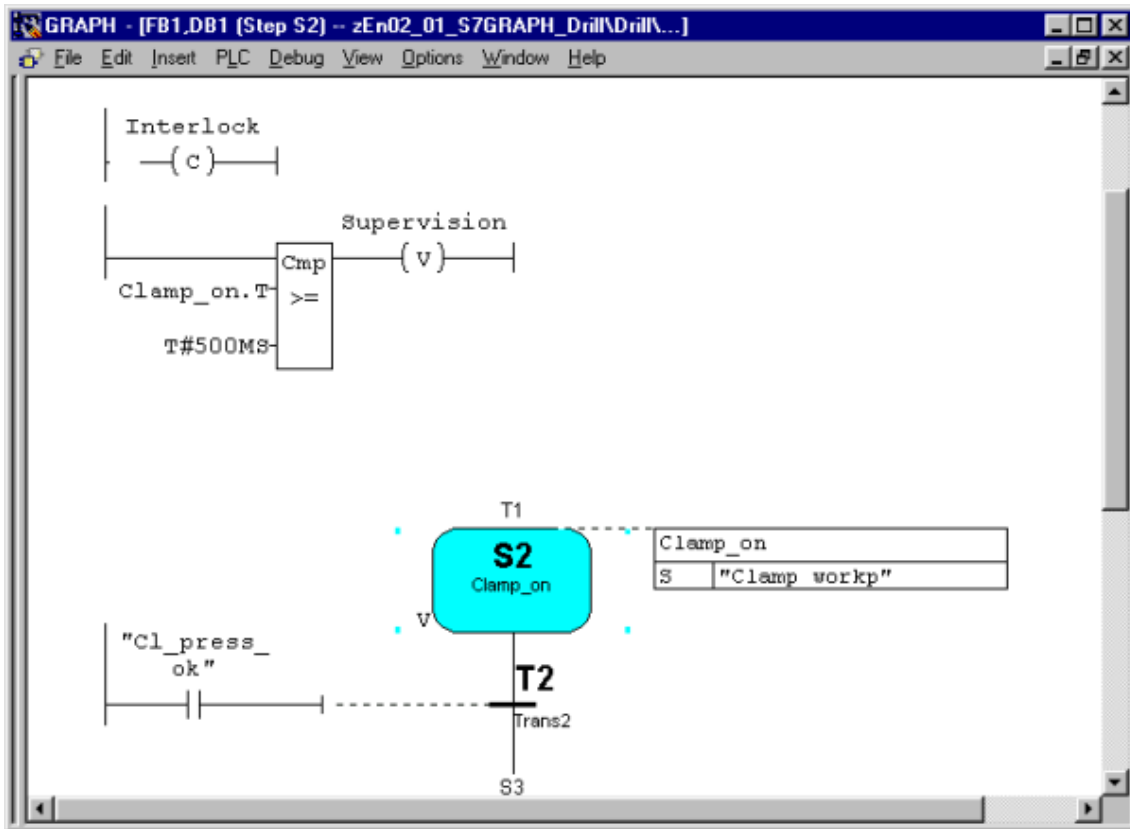

3.10 Specifying the Standard Function Block

Executability of the S7 Graph FB

S7 Graph has two options available for creating FBs.

- Full code:
The entire code required to execute each S7 Graph FB is included in the FB. If you have several S7 Graph FBs, this means a considerable increase in memory requirements.
- Standard FC required:
To reduce memory requirements, S7 Graph has the two following alternatives: You use a standard FC containing the main code sections for all FBs. This FC is copied to your project automatically when you select this option. The FBs produced using this method are considerably smaller.

For this example, use the compilation option "Full code".

The most suitable FC depends on the performance of your CPU. Select one of the following standard FCs:

FC Number	Functionality
FC72	As default, you work with FC72. Remember, that your CPU must be capable of processing blocks with more than 8 Kbytes.
FC70/FC71	These two FCs are less than 8 Kbytes in size and can therefore be loaded on a smaller CPU. FC70 uses the diagnostic functionality of SFC17/18 and can only be used on CPUs that have these functions available. If your CPU does not have these functions, you must use FC71 and do without diagnostic capability. If you want to check whether or not your CPU contains these SFCs, select the menu command PLC > Obtainable Nodes in the SIMATIC Manager or click the corresponding button in the toolbar. Open the "Blocks" folder in the S7 program.
FC73	This block requires less than 8 Kbytes of memory so that it can be executed on all CPUs. Using this FC considerably reduces the memory requirements of the S7 Graph FBs. You must also select the option "Interface Description: Memory minimized" in the block settings. The following restrictions, do, however, apply: The blocks created do not have diagnostic capability When you monitor the sequential control system, you will see the status display only for the selected active element.

Setting the Executability

Select the menu command **Options > Block Settings** and specify that the S7 Graph FB can be executed with a standard FC in the Compile/Save tab. Enter the FC number that matches the performance of your CPU.

The block is automatically copied to the user project if you select FC70/71, FC72 or FC73 as the block number and there is not yet an FC with this number in the target project. If you want to use a different number for the standard block, you must copy and renumber yourself.

3.11 Saving and Closing the Sequencer

When you save the sequencer, it is automatically compiled.

1. Select the menu command **File > Save**.

Result: The "Select Instance DB" dialog box is opened with the default instance DB (DB1).

2. Accept the settings by clicking "OK".

Result: The instance data block is automatically created in the "Blocks" folder.

Note

The warning "S1 without content" in the compiler log simply means that no action is programmed in step 1.

3. To close the sequencer, select the menu command **File > Close**.

3.12 Including the Sequencer in the STEP 7 Program

Programming OB1

The sequential control program for the drill is called and started in organization block OB1. You can create OB1 in LAD, FBD, STL or SCL (here it was created in LAD). Program OB1 as shown in the following diagram. Follow the steps below:

1. Open the "Blocks" folder in the "Drill Program" S7 program in the SIMATIC Manager.
2. Start the LAD/STL/FBD editor by double-clicking OB1.
3. With the menu command **View**, select the programming language LAD.
4. Select segment 1 and insert the sequencer call using the program element catalog by double-clicking FB1 (Seq_drill).
5. Type in the name of the corresponding instance data block (IDB_Seq_drill) above the LAD box.
6. Select the input parameter INIT_SQ, insert a normally open element using the "LAD" toolbar and label it M0.0 ("INIT_SQ"). Using this parameter, you can set the sequencer to the initial step (in the example step 1) in the online mode.
7. Select the menu command **File > Save** and close the organization block with the menu command **File > Close**.

Note

All other block parameters can be ignored for the example.

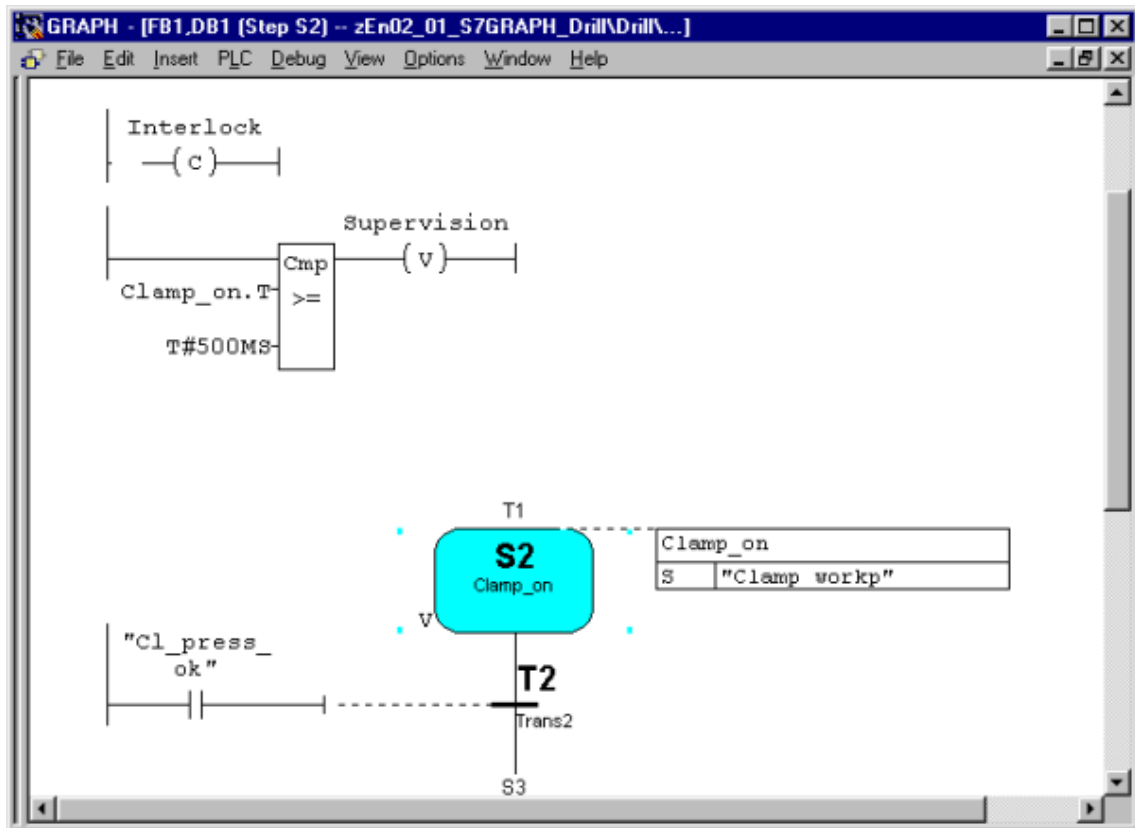

3.13 Downloading the Program to the CPU and Testing the Sequencer

Downloading the User Program

To allow you to download the program to the CPU, you must download all the blocks (DB1, FB1, OB1, FC70/71, FC72 and/or. FC73) to the CPU of the programmable controller in the SIMATIC Manager. Follow the steps outlined below:

1. Open the "Drill Program" S7 program in the SIMATIC Manager and select the "Blocks" folder.
2. Select the menu command **PLC > Download**.

Caution

It is best to download the S7 Graph block in the STOP mode since following downloading of the instance DB, the sequencer is automatically set to the initial state.

You should only download S7 Graph blocks in the RUN-P mode when the sequencer is in the initial state or in the OFF state. If you download the blocks the sequencer in a different state, for example when overwriting an old block, problems may occur in the synchronization of the sequencer with the process.

Testing the User Program

To test the user program, you require an online connection to a CPU.

3. Open the project window in the SIMATIC Manager.
4. Open the sequencer by double-clicking FB1.
5. Select the menu command **Debug > Monitor**.

Result: The program status is displayed (the initial step is active). Active steps are displayed in color.

Caution

A monitoring time is programmed in step 2. If the step activation time exceeds the configured monitoring time (500 ms) in the supervision condition, the system recognizes a supervision error and the disturbed step is displayed in red. If a fault occurs, you must first satisfy the condition for progressing to the next transition. Using the PG function **Debug > Control Sequencer** you can then enter an acknowledgment (see also "Control Sequencer").

This does not apply to the inching mode, since the step enabling condition must be satisfied and the acknowledgment received within one cycle.

3.14 Test Function: Control Sequencer

Control Sequencer is a test function with which you can test the sequencer in S7 Graph in all modes. All the settings and entries for the dialog box have the same effect as the corresponding FB parameters.

The entries in the "Control Sequencer" dialog box can be different from the settings you used to compile the sequencers. The dialog box settings have priority.

"Control Sequencer" Dialog box

The "Control Sequencer" dialog box is used both as an output field that displays the current settings and as an input field in which you can change the current status.

If you acknowledge an error, initialize the sequencer, or want to change the step in the manual mode, call the dialog box with the menu command **Debug > Control Sequencer**.

Acknowledge

If the "Acknowledge errors" option is clicked, you acknowledge a pending error message with the "Acknowledge" button. In this way, you can acknowledge a disturbance caused, for example, by the configured monitoring time in Step 2 being exceeded.

Note, however, that before you acknowledge the error you must make sure that the supervision or interlock conditions that led to the error are no longer satisfied.

After an error has occurred, you can enable the next step in the sequencer by satisfying the step enable condition because the last step enable condition in the cycle in which you acknowledge has priority over the supervision. You must nevertheless acknowledge the error.

If the error was caused because the undisturbed activation time **Step name.U** has exceeded the configured monitoring time, you can move on the sequencer by clicking the "Acknowledge" button.

This is possible because the **Step name.U** variable is set to "0" when you acknowledge.

Initialize

With the "Initialize" button, you can restart the sequencer completely with the defined initial step.

Setting the Mode

If you click one of the round option buttons, you switch the sequencer to the selected mode.

You can, for example, run your sequencer in the manual mode instead of the automatic mode. In the manual mode, you can activate or deactivate any step. Follow the steps outlined below:

1. Enter the step number of the step you want to process in the "Step number" box or simply click the required step.
2. Select the action to be executed with the step:
 - Activate The selected step is activated even if the preceding transition is not satisfied.
 - Deactivate The selected step is deactivated.

Note that before you activate a step you must first deactivate the currently active step since only one step can be active at any one time in a linear sequencer. In other words, you can only activate the required step when you have deactivated the currently active step.

If you have set a new mode, the original mode is indicated in bold face.

After you have controlled your sequencer in the manual mode, you can return to the automatic mode and close the "Control Sequencer" dialog box.

3.15 Modifying the Sequencer

Often, a program does not run as required at the first attempt. This means that changes and modifications are required. This is also the case in our sample program. The configured monitoring time in Step 2 is too short and the program hangs at this step. The following section explains how to make the required changes. You must first change to the "offline" mode.

Modifying the Monitoring Time

The monitoring time configured in Step 2 is 500 ms. To give you more time for setting the "CI_press_ok" variable, change the monitoring time to 5 s as explained below:

1. Double-click on step 2 to change from the "sequencer" view to the "single step" view.
2. Close the status by selecting the menu command **Debug > Monitor** or clicking the following button: .
3. Enter the value 5 s for the monitoring time.
4. Save the sequencer with the menu command **File > Save**, since the sequencer must be recompiled.

Downloading the Modified Sequencer

Once you have compiled the sequencer, you must download it to the CPU. You can download the sequencer in the SIMATIC Manager or in the S7 Graph editor. In the S7 Graph editor, follow the steps outlined below:

1. With the FB open, select the menu command **PLC > Download** or click on the **Download** button . The "Download" dialog box is opened.
2. Accept the defaults by clicking "OK".
3. Confirm the prompt to overwrite the existing blocks.

Include Instance DB

If you have not cleared the system default "Include Instance DB", S7 Graph checks whether the instance DB has changed since it was last downloaded and whether it must be updated. The option "Download with Instance DB" is clicked in the "Download" dialog box.

Otherwise, S7 Graph does not check the instance DB and leaves you to decide whether or not to download the instance DB again. The option "Download with Instance DB" is not clicked in the "Download" dialog box.

Restarting the Status

To be able to monitor or control the sequencer again, restart Status by selecting the menu command **Debug > Monitor** or by selecting the **Monitor**  button.

